

Please View:

SWTL power transfer [demo video](#) for a practical demonstration of power transfer over SWTL at 2m.

Note that this is neither “G-Line” nor an invention that Tesla described.

Demonstration

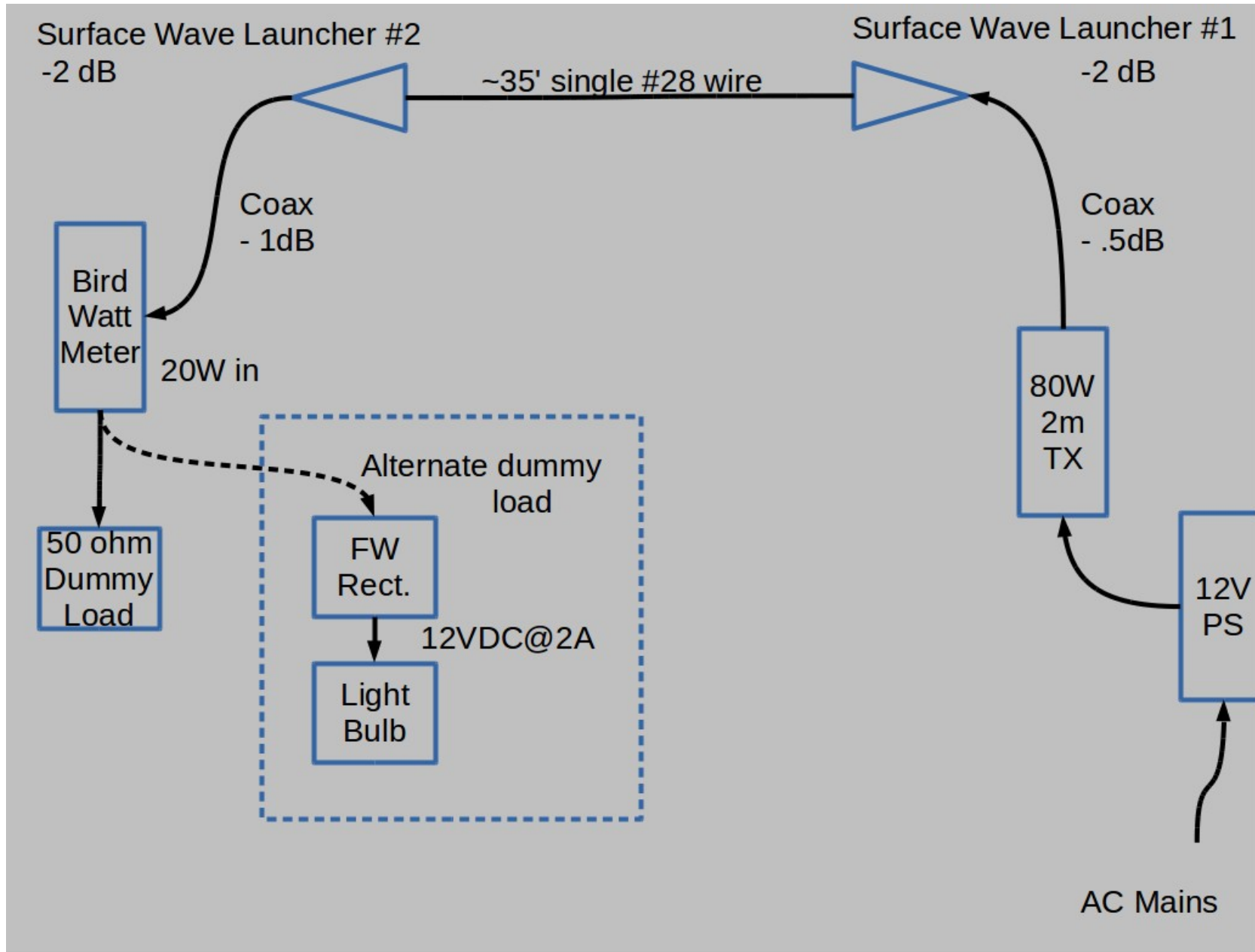

Huh? Really?

There may be a few questions:

- 1)“Is this a trick? Is there a battery in the box?”
- 2)“Isn’t this just G-Line?”
- 3)“Why doesn’t it act like an antenna?”
- 4)“What’s really going on?”
- 5)“If this really is such a fundamental mode, why hasn’t it been discovered before now?”

The slides that follow may help answer some of these questions

Why Hasn't This This Been Discovered Before?

This is the truly fun question

- 1) Theory recognized, practicality missed by Stratton
- 2) Theory missed, practicality obfuscated by Goubau
- 3) Radiation not understood by anyone
- 4) Our Models are WRONG.

Perhaps to Be Continued in "Part 2" !

What's Wrong with Coax?

(Slides that follow excerpted from “[Introduction to the Propagating Wave on a Single Conductor](#)”)

- Undersea cables used since mid-1800's
- Patents by Tesla & Marconi late 1800's
- Ampere & Gauss's Laws
- Heaviside's Telegrapher's Equation

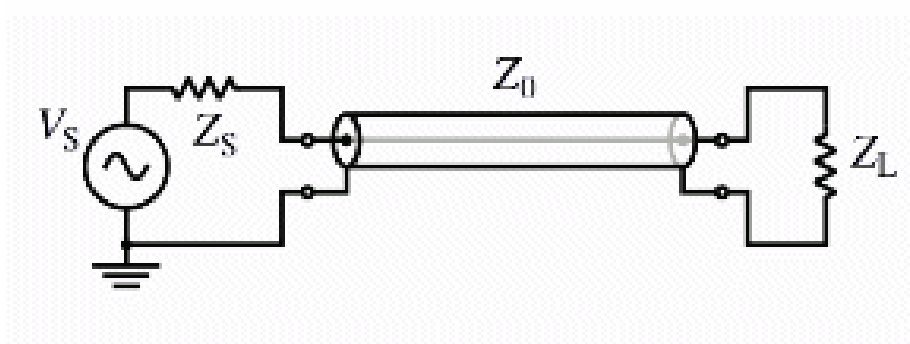
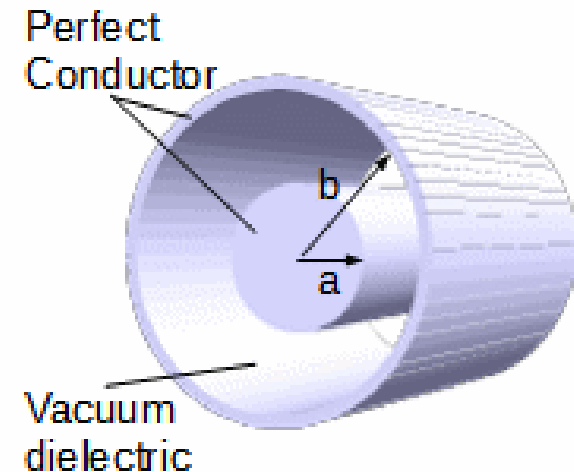

Infinitesimal Length of Lossless Line

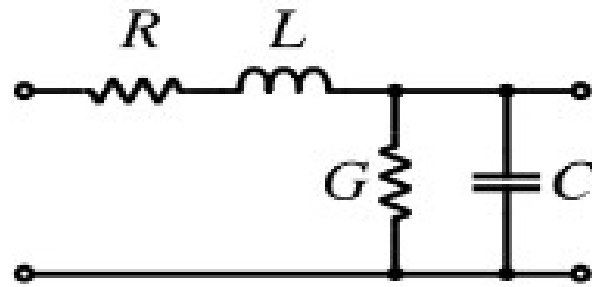

$$L_l = \frac{\mu}{2\pi} \ln\left(\frac{b}{a}\right)$$

and Gauss's law to find the capacitance per unit length

$$C_l = \frac{q}{Vl} = \frac{2\pi\epsilon}{\ln\left(\frac{b}{a}\right)}$$

this describes a line with an entirely real characteristic impedance² of

$$Z = \sqrt{\frac{L_l}{C_l}} \text{ ohms}$$

Characteristic Impedance of Coax is Due to Geometry

$$Z_{TEM} = \frac{1}{2\pi} \sqrt{\frac{\mu}{\epsilon}} \ln\left(\frac{b}{a}\right) \approx 60 \ln\left(\frac{b}{a}\right)$$

where

$\mu \stackrel{\text{def}}{=} 4\pi \times 10^{-7}$ Henry/meter $\approx 1.2566 \mu\text{H/meter}$, permeability of a vacuum

$\epsilon = \frac{1}{c^2 \mu}$ Farad/meter ≈ 8.8542 pF per meter, permittivity of a vacuum

Per ARRL License Manual, Handbook etc:

$$\text{Coaxial Cable, } Z = 138 * \log\left(\frac{b}{a}\right)$$

BUT

Energy Can't Propagate Faster Than c !

A homogeneous plane wave in an isotropic medium has an intrinsic impedance'

$$Z = \sqrt{\frac{\omega \mu}{\omega \epsilon + i \sigma}}$$

in free space where

$$\sigma = 0$$

this reduces to

$$Z = \mu c = \sqrt{\frac{\mu}{\epsilon}} \approx 120 \pi \text{ ohms}$$

Free Space, $Z = 377 \text{ ohms}$

Coax Isn't Solely TEM

For $b/a > 535$ in “regular old TEM coax” propagation would need to be faster than the speed of light!

The standing transmission line equation for coaxial cable where:

$$\gamma = \alpha + j\beta$$

is the propagation constant. α describes the attenuation while β describes the phase, per unit length of line. The propagation constant for the principle mode can be shown to relate to the components in Illustration 2 by

$$\alpha + j\beta = \sqrt{(R + j\omega L)(G + j\omega C)} \quad (11)$$

Is WRONG!

There's ANOTHER Mode!

Something else must be going on.

Theory* says that two principle modes are possible, TEM_{00} and TEM_{00}

A TM_{00} mode ***not involving the outer conductor*** also exists in coaxial cable !

***Animation of E fields on simple SWTL system,
produced by 3D microwave structure simulator (HFSS)***

*Julius Adams Stratton (MIT), *Electromagnetic Theory*, 1941

Why Isn't This an Antenna?

(Slides that follow excerpted from “ [A New Antenna Model](#)”)

Contrary to “common wisdom”, current in a conductor is not synonymous with radiation - witness coaxial cable, balanced line and many other transmission line types for which symmetry provides cancellation in the far field.

Coax outer conductor prevents radiation because it provides a balancing/negating current rather than because it hides the acceleration of charge (current) in the center conductor from being “seen” outside of the cable. Common mode current on coax with its attendant radiation is a deviation from this mode of operation.

ARRL Antenna Book “Long Wire”

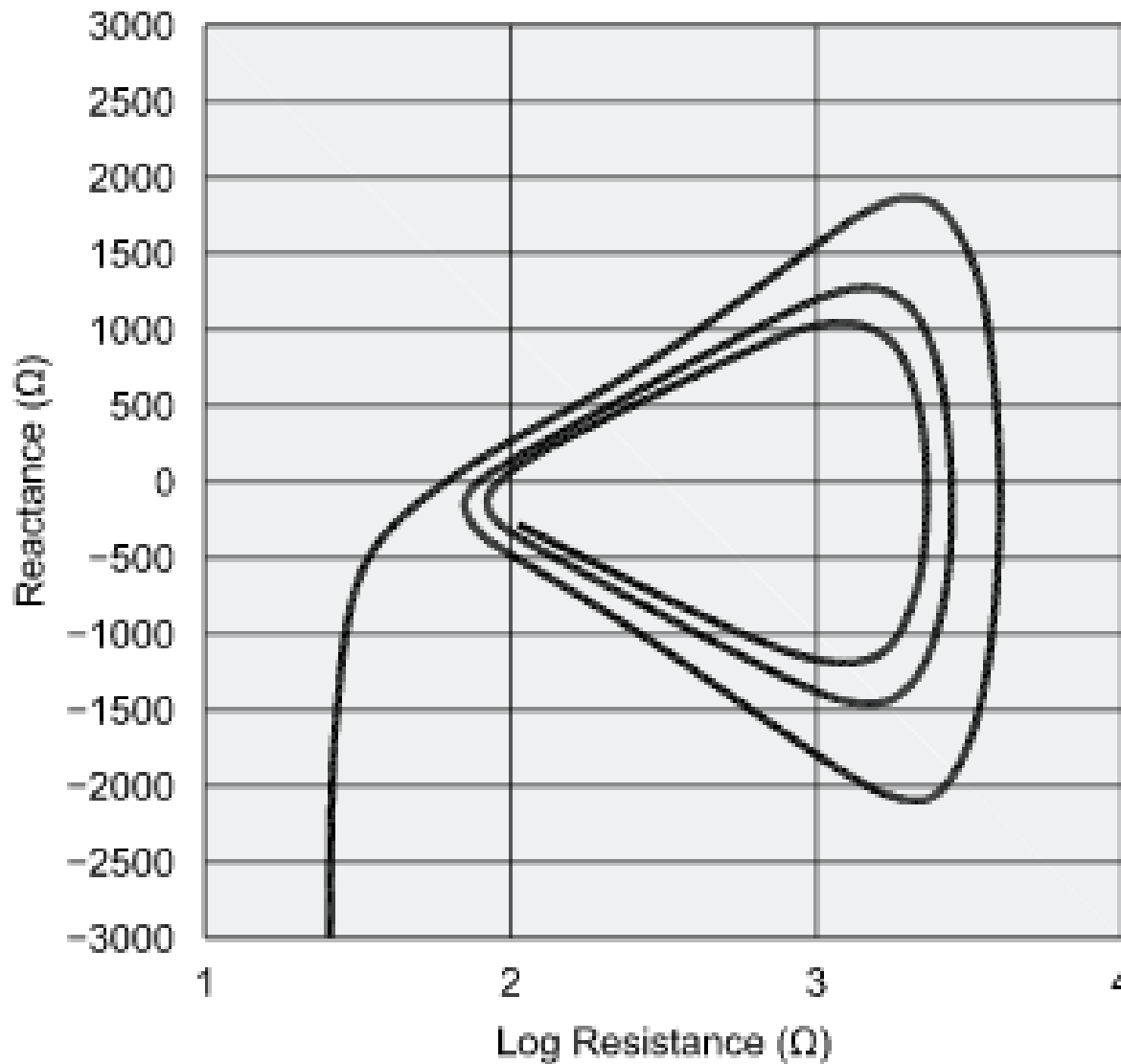

“Long Wire” Acts Like a Non-Radiating Transmission Line

If it was radiating, at some point any additional length would have no effect. This is NOT what is either modeled or observed, as demonstrated by the measurement below

SWR of 33 foot Vertical with Tapered Ends, 2 foot Disk and 8 foot Ground Rod, 200 Ω Reference Impedance

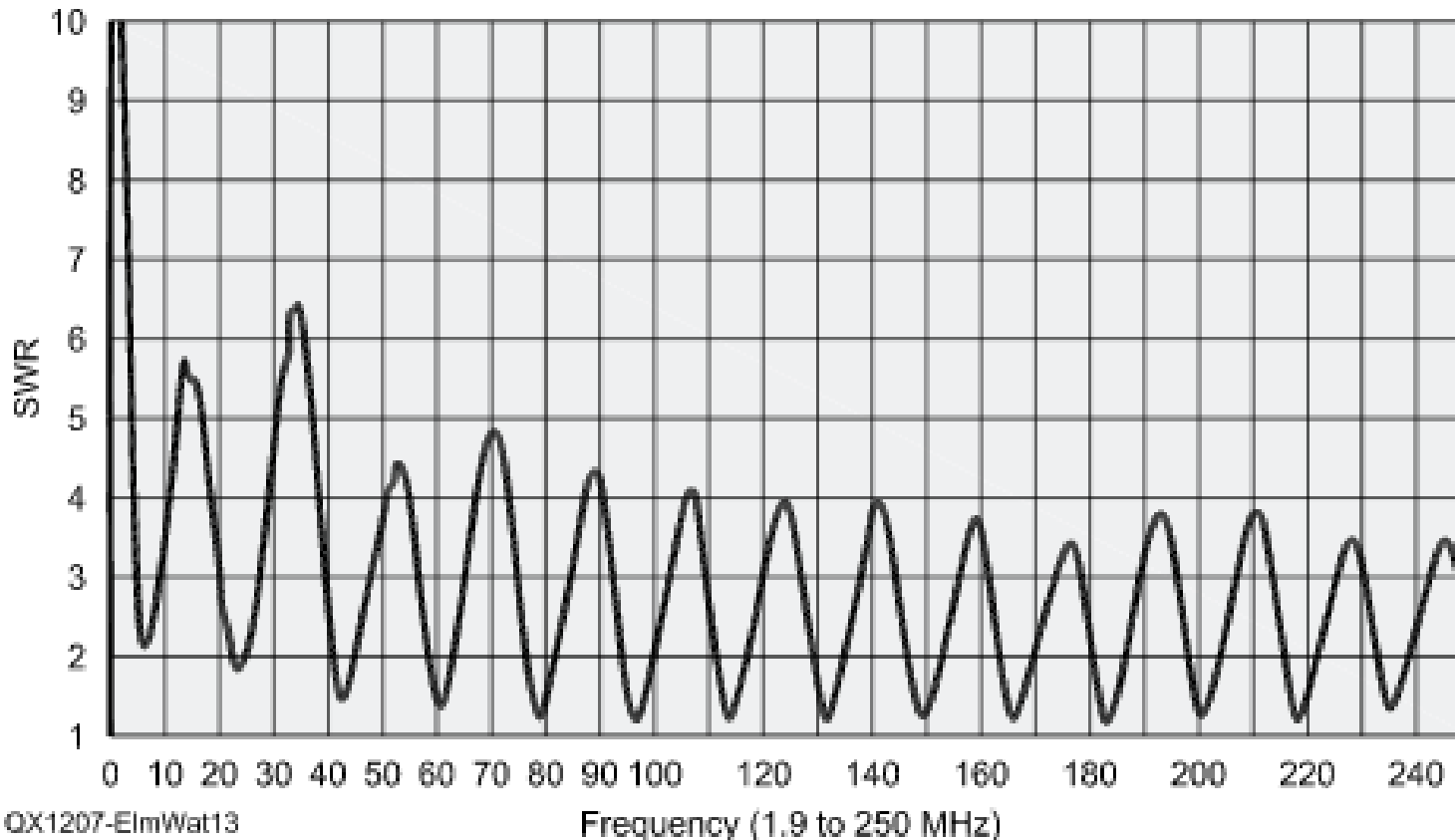

Dipole Modeled Over Broad Range

QX1207-ElmWat06

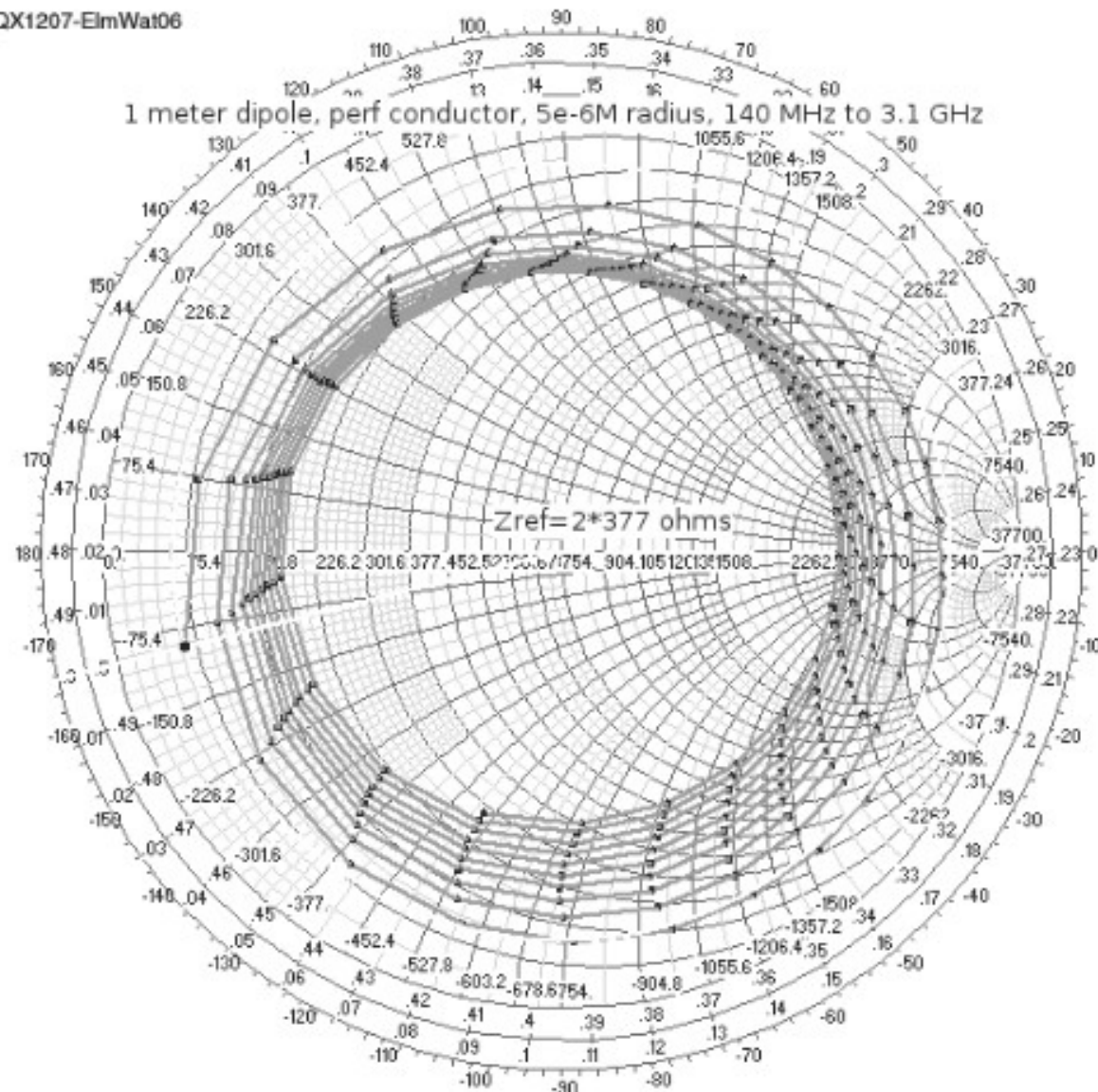

Dipole As a SWTL

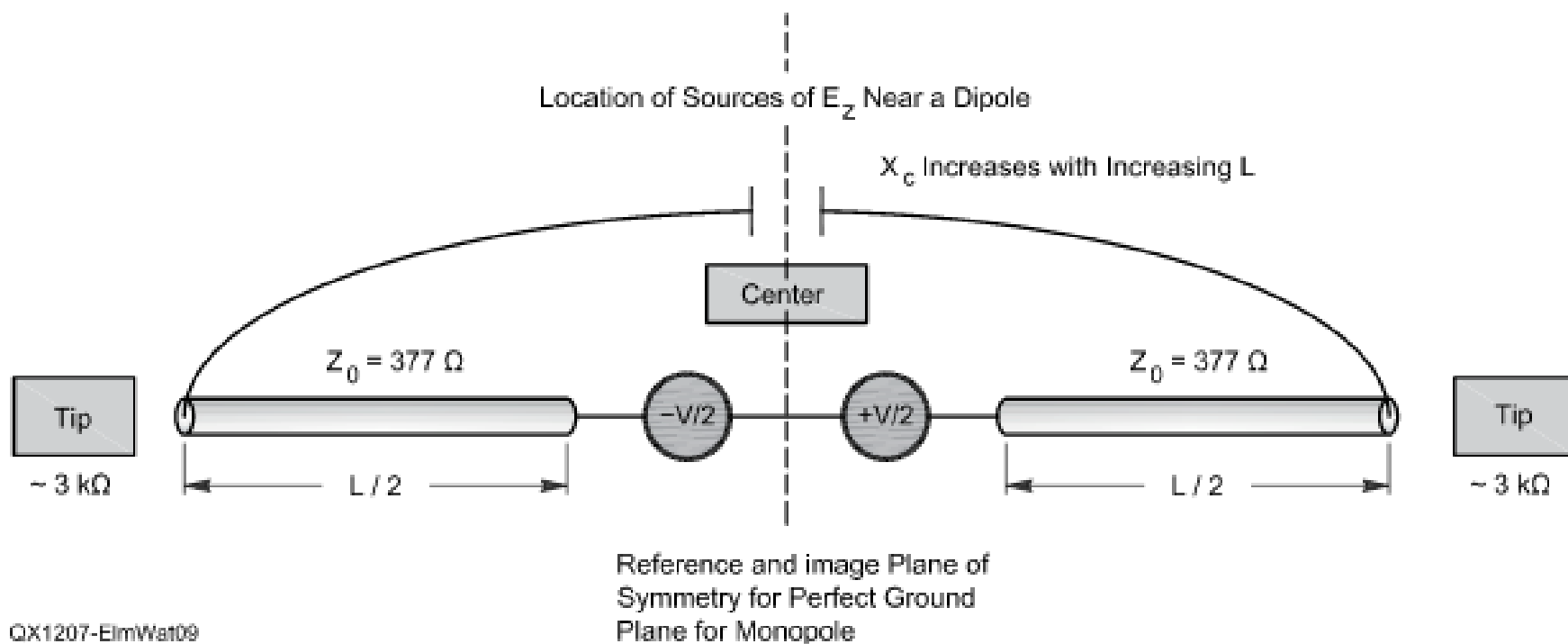

Why Isn't This "G-Line"?

- Goubau *Required* slowing the wave down by means of insulation or special conditioning

From US Patent #2685068 (1954):

- "object of my invention is to provide a surface wave transmission line comprising elongated conductive means having its outer surface conditioned, or modified, so as to reduce the phase velocity of the transmitted energy to thereby concentrate the field of the transmitted wave adjacent the conductor."
- "By means of the present invention the field of the surface wave is concentrated adjacent the conductor."

He thought an otherwise expanding wave front was made to "hug" the conductor if the conductor was made suitable. He did not recognize that there was actually a TM mode present, a solution to Maxwell's Equations, which did not have the constraints he put on G-Line.

He said G-Line needed:

- Reduced wave propagation velocity
- Special conductor, no bare wires (maybe "sort of" above 5 GHz)
- Launchers with mouths a considerable fraction of a wavelength
- No low frequency operation

Goubau Was Wrong

- No “concentration” of field is involved
- Conductor does **not** require conditioning
- TM_{00} wave **can** travel at c
- Bare conductor **can** work well below 5 GHz, even HF
- Small launchers **are** possible

Almost certainly, Goubau’s invention was not operating the way he thought it was nor was it restricted in the ways he, and everyone else since, thought.

Multiple US and International patents have been granted which acknowledge these differences.

For more practical and theoretical information about SWTLs please see [N6GN pages](#).